

**HANDY MANUAL**

# **PAPER & PULP INDUSTRY**



## **Output of a Seminar on Energy Conservation in Paper and Pulp Industry**

*Sponsored by*

**United Nations Industrial Development Organization  
(UNIDO)**

*and*

**Ministry of International Trade and Industry  
(MITI), Japan**

*Hosted by*

**Ministry of Science,  
Technology and Environment,  
Thailand**

**The Department of  
Energy, Philippines**

*Organized by*

**The Energy Conservation Center (ECC), Japan**

**1993**

**Thailand**

**Philippines**

## PREFACE

The conservation of energy is an essential step we can all take towards overcoming the mounting problems of the worldwide energy crisis and environmental degradation. In particular, developing countries are interested to increase their awareness on the inefficient power generation and energy usage in their countries. However, usually only limited information sources on the rational use of energy are available.

The know-how on modern energy saving and conservation technologies should, therefore, be disseminated to governments and industrial managers, as well as to engineers and operators at the plant level in developing countries. It is particularly important that they acquire practical knowledge of the currently available energy conservation technologies and techniques.

In December 1983, UNIDO organized a Regional Meeting on Energy Consumption as well as an Expert Group Meeting on Energy Conservation in small- and medium-scale industries for Asian countries. During these meetings, it was brought out that, for some energy intensive industries, savings up to 10% could be achieved through basic housekeeping improvements, such as auditing and energy management.

All these experiences brought UNIDO to prepare a regional programme on the promotion and application of energy saving technologies in selected subsectors, since the rational use of energy calls for a broad application of energy conservation technologies in the various industrial sectors where energy is wasted. One of these energy intensive industrial sectors to be considered to improve efficiency through the introduction of modern energy conservation technologies is the pulp and paper industry.

The pulp and paper industry consumes much energy and water. The pulp and paper industry is also noted for great percentage of the energy cost in the total production cost.

In the pulp and paper industry, appreciable amounts of energy could be saved or conserved by regulating and insulating the temperature in the steam pipes, modifying the equipment to recover heat from the various units in the process of pulping and paper-making and effective use and reuse of paper machine white water.

Currently, UNIDO is implementing this Programme with the financial support of the Japanese Government, in selected Asian developing countries. This programme aims at adopting these innovative energy conservation technologies, developed in Japan, to the conditions of developing countries.

In this programme, we are considering that the transfer of these technologies could be achieved through:

- (i) Conducting surveys of energy usage and efficiency at the plant level;
- (ii) Preparing handy manuals on energy management and energy conservation/saving technologies, based on the findings of the above survey;
- (iii) Presenting and discussing the handy manuals at seminars held for government officials, representatives of industries, plant managers and engineers;
- (iv) Disseminating the handy manuals to other developing countries for their proper utilization and application by the industrial sector.

The experience obtained through this programme will be applied to other programmes/projects which involve other industrial sectors as well as other developing countries and regions.

UNIDO has started this programme with the project US/RAS/90/075 - Rational Use of Energy Resources in Steel and Textile Industry in Malaysia and Indonesia. This was followed by project US/RAS/92/035 - Rational Use of Energy Saving Technologies in Pulp/Paper and Glass Industry in Philippines and Thailand.

The present Handy Manual on Pulp and Paper Industry was prepared by UNIDO, with the cooperation of experts from the Energy Conservation Center (ECC) of Japan, on energy saving technologies in the framework of the above-mentioned UNIDO project. It is based on the results of the surveys carried out, the plant observations and the recommendations and suggestions emanating from the Seminars on Energy Conservation in the Pulp and Paper Industry; held under the same project in January and February 1993 in Bangkok, Thailand and Manila, Philippines respectively. The handy manual will not only be interesting for government and representative from industry, but it is, in particular, designed for plant-level engineers and operators in developing countries as a help to improve energy efficiency in the production process.

Appreciation is expressed for the valuable contribution made by the following institutions to the successful preparation and publication of the manual mentioned above:

The Department of Energy, Philippines

Ministry of Science, Technology and Environment, Thailand

Ministry of International Trade and Industry (MITI), Japan

The Energy Conservation Center (ECC), Japan

# CONTENTS

## Preface

1. production process of the pulp and paper industry .....	1
2. Consumption in the pulp and paper production process .....	3
3. Promotion of energy conservation technology .....	4
3.1 Waste-saving and effective use of energy .....	4
3.2 Energy conservation technology in the pulping process .....	5
3.3 Use of waste paper in the pulping process .....	8
3.4 Energy conservation technology in the papermaking process .....	11
3.4.1 Paper breaking .....	12
3.4.2 Impurities .....	15
3.4.3 Press dewatering .....	18
3.4.4 Effective use of white water.. .....	25
3.4.5 Drying .....	31
3.5 Energy conservation technology in refining process .....	33
3.5.1 Unit power consumption of refiner .....	35
3.5.2 Effective refining energy .....	36
4. Energy conservation in the pulp and paper industry .....	37
4.1 Energy conservation in the papermaking process .....	38
4.2 Energy conservation in the pulping process .....	39

## **1. Production process of the pulp and paper industry**

The pulp and paper industry has been consuming much energy and water ever since Cailun (an inventor of paper in ancient China) invented paper in A.D. 105. He crushed the bark of the shrub with a stone mill to extract fibers, and separated the single fibers by washing them in water. When they were uniformly distributed underwater, they were dewatered and formed by a drain board. Then the wet paper web was dried in the sun for a long time, and final paper products were obtained.

The basic principle in the manufacturing process of the pulp and paper industry today has undergone almost no change, but industry has developed into a process industry constituting the continuous production processes. Figure 1 shows an example of the production process.

The pulp and paper industry consumes much energy and water. The pulp and paper industry is also noted for a great percentage of the energy cost in the total production cost.

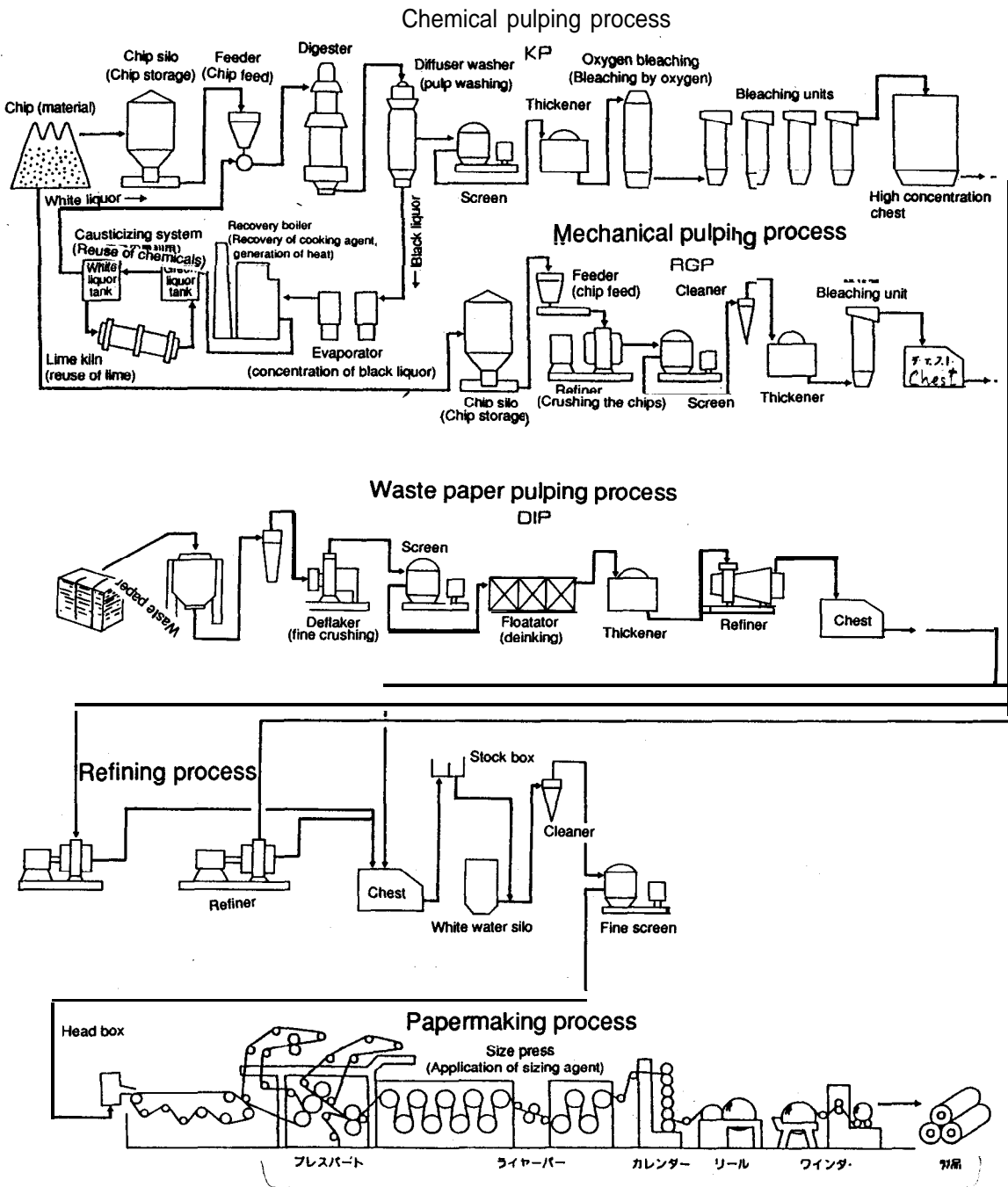

Figure 1 Overview of pulp and paper manufacturing processes

## 2. Consumption in the pulp and paper production process

It is extremely difficult to grasp the energy consumption pattern in the entire pulp and paper industry. Since the pulp process differs considerably depending on production items and composition of the material woods, it is difficult to define the representative pulping process. Table 1 represents the unit consumption of the consumption pattern of steam and electric power summarized according to the recent data in Japan, using the model of the integrated fine paper mill for general printing paper and writing paper.

**Table 1 Energy consumption pattern of pulp and paper processes in an integrated fine paper mill**

Energy		Process		Bleaching	Paper machine	Others
		Evaporator Causticizing	Cooking Washing			
Steam	ton/paper ton	1.5	1.0	0.4	3.0	0.3
		5.9 (95%)				
Electric Power	kWh/paper ton	Cooking Washing	Bleaching	Refining	Paper machine	Others
		140	150	240	600	220
		1,130 (84%)				

The paper machine, which is the greatest consumer of steam, followed by the black water concentration process, is also the greatest consumer of electric power.

### **3. Promotion of energy conservation technology**

#### **3.1 Waste-saving and effective use of energy**

The paper and pulp production equipment as a process plant is operated by electric power and thermal energy. Energy conservation is meant not to reduce the energy for operation, but to ensure “waste-saving” and “effective” use of energy, thereby resulting in reduced energy for operation. “Waste-saving” and “effective” use of energy is ensured by field technology.

“Waste-saving” use is provided by continuous operation from the start of operation to the day of shutdown determined by the production schedule, without the paper and pulp production being interrupted by the machine and steam system failure, electric failure due to accidents, or paper breaking on the paper machine.

This continuous operation requires:

- 1) Quality control system which permits the constant production of stable good-quality products, without products rejected in the inspection, and
- 2) Preventive maintenance (PM) system which eliminates the possibility of machine and equipment troubles or electric failure due to electric equipment failure.

The so-called total control system must be implemented every day as part of the routine work.

“Effective” use is to prevent dissipation and waste of heat of the energy supplied to the system or to recover it, and to provide uniform hydration in the cross direction on the wire part, press part and dryer part by ensuring the following equipment functions:

- 1) Improving the rate of circulated use of white water to reduce the wasteful discharge, which leads to the reduction of new water used

The electric power for the pump, agitator and refiner is converted into thermal energy to raise the pulp slush temperature. Discharge of the white water means discharge of heat. Maintenance of a high system temperature by effective circulation of the white water will improve the dewatering rate and reduce the amount of steam used for drying. Effective circulation of the white water will also improve the yield rate.

- 2) Uniform nip pressure of the pressure to be ensured in the cross direction  
Effective energy reduction cannot be gained by mere pressure increase. Uniform dewatering is ensured only by uniform pressure in the cross direction, which, in turn, will permit uniform drying and minimize the possibility of paper breaking.
- 3) Three functions of showering, squeezing and dewatering to be used to wash the press felt  
The felt cleaned and dewatered to have low-moisture content promotes suction of water in the pressing process. The use of hot water for shower provides effective washing and prevents the wet web temperature from lowering.
- 4) Dryer surface to be kept clean by effective use of the doctor thereby ensuring high heat conductivity
- 5) Drain within the dryer cylinder to be eliminated completely  
Drain has a low heat conductivity, so it decreases heat efficiency.
- 6) Ventilation inside the dryer part to be uniform on the front and back, dryer pocket in particular to be eliminated completely

### **3.2 Energy conservation technology in the pulping process**

The following describes the concept of “wastesaving” and “effective” energy conservation, with particular reference to the chemical pulping kraft process.

Figure 2 shows the case of batch cooking.

Cooking Control Gas Heat Recovery

Blow Gas Heat Recovery

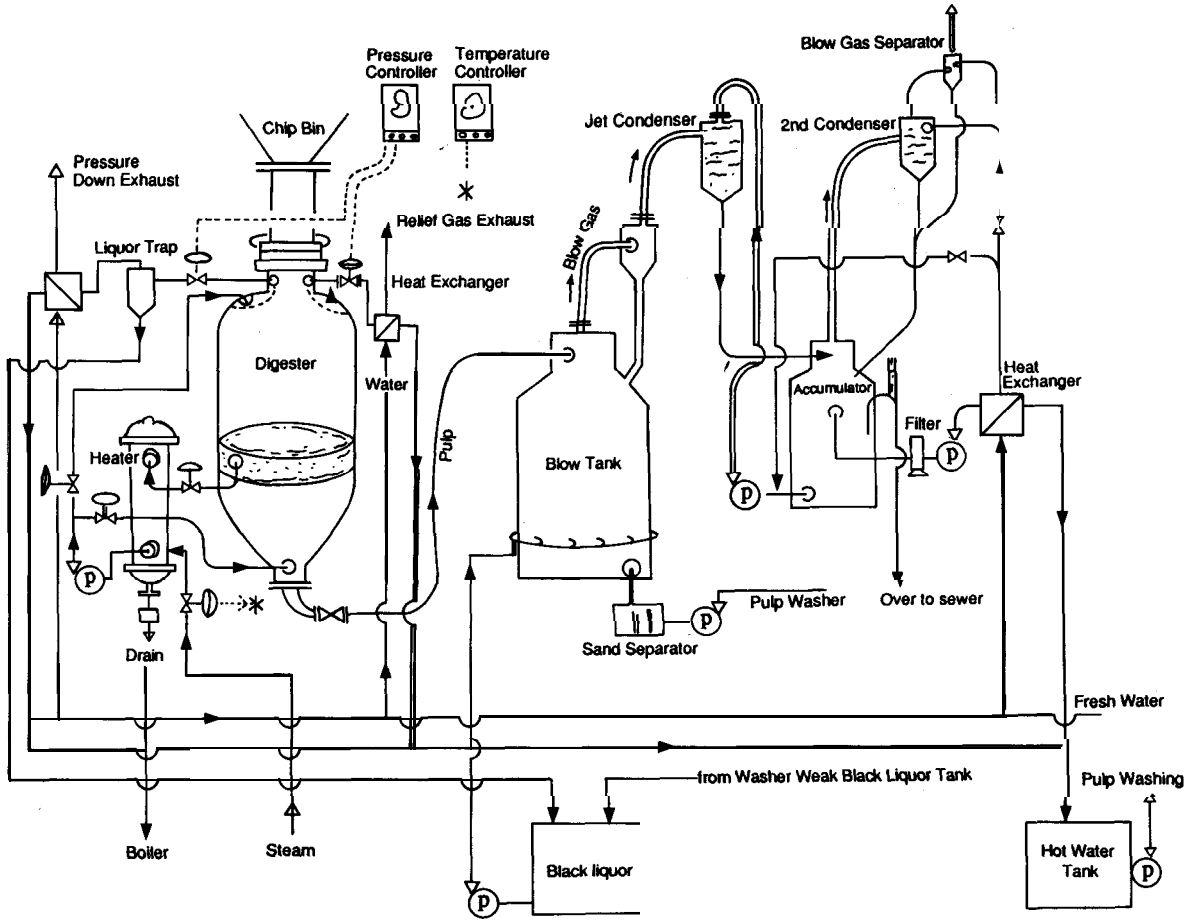

Figure 2 Batch cooking and heat recovery system

Much energy is consumed in the chip pulping reaction.

Heat required for reaction must be given as effectively as possible, and the heat should be removed upon termination of the reaction; otherwise, it may affect the quality and yield. The following points should be noted for this series of reaction:

(1) **Rise of reaction temperature**

The cooking liquor is heated by the steam of the multi-tube heater, and the temperature inside the digester is raised. In the indirect heating method, scales which have low heat conductivity will be attached on the liquor side of the heater. Since the scales waste steam, attached scales should be removed on a periodic basis.

(2) **Control of reaction requirements**

When the reaction temperature has risen, non-condensable gas will be produced, preventing the reaction. This gas must be removed. When it is removed, heat contained in the gas is recovered by the heat exchanger.

(3) **Pressure reduction**

Immediately after the reaction, the pressure is reduced and the temperature is lowered. The pressure reducing speed is increased when a great amount of this high-temperature exhaust gas is cooled by the heat exchanger. At the same time, the heat contained in the gas can be recovered as hot water. Scales and pulps are attached to the gas discharging strainers provided on the gas side of the heat exchanger and on the top of the digester, and cause the gas discharge speed to be lowered. Periodic inspection and cleaning are essential to improve the efficiency of the strainer and heat exchanger.

(4) **Blowing**

When the pulp in the digester is to be blown out by the internal pressure, the blow speed is increased and the blow time is decreased by increasing the differential pressure of the exhaust gas. Pulps are attached to the jet condenser which absorbs a great amount of gas and the thermal accumulator. Pulps also enter the heated dirty water, so they are attached to the heat exchanger for heat recovery. Since the pulps feature extremely small heat conductivity, they must be removed periodically.

For energy conservation in the pulp division, effective supply of energy for pulping must be ensured, and the extra energy required for pulping should be recovered as effectively as possible, and should be put to reuse.

### 3.3 Use of waste paper in the pulping process

The pulp and paper industry is highly evaluated for its effective reuse of the waste paper and for its attitude toward effective use of precious resources on earth. The waste paper once used only as paperboard has come to be used as newspaper, writing paper and toilet paper by the development of deinking technology (see Figure 1), which has permitted manufacture of the products having almost the same quality as the new one. Such efforts have resulted in the utilization rate and recovery rate of as high as over 50% as shown in Figure 3.

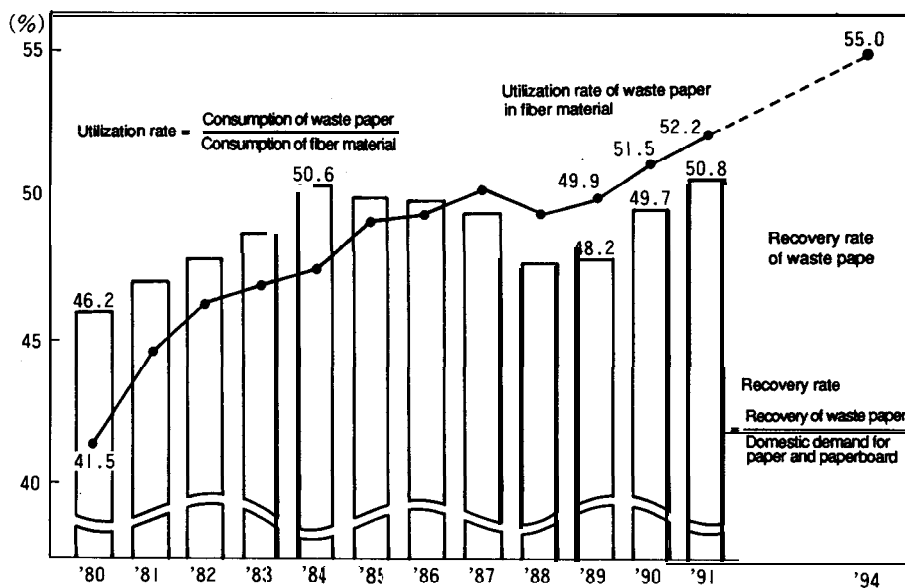

Source: PPI

Figure 3 Recovery and utilization rates of waste paper in Japan

This effort means a great contribution not only to energy conservation, but also to a reduction in the amount of solid waste generated in the community and reduction in the refuse processing costs, thereby contributing to the global environment protection.

(1) **Waste paper pulping**

In the deinking process, deinking agent is added after the defibration of the waste paper, and the paper is subjected to maturation for a sufficiently long time; then, the ink is removed from the paper by kneading action. The paper is put into the bleaching equipment, from which the deinking pulp (DIP) featuring a high degree of whiteness is obtained.

(2) **Energy conservation effect of waste paper**

Energy consumption in pulping the waste paper is said to be about one-third of that in wood pulping.

Table 2 illustrates the unit energy consumption for waste paper pulping.

**Table 2 Unit energy consumption for waste paper pulping**

Pulp	Waste paper	Unit	Steam	Electricity
			Unit: t/pulp t	Unit: kWh/pulp t
Defiberized pulp	Corrugated container waste		0.025	230
	Old news, old magazines		0	250
Deinking pulp (DIP)	Old news		0.3	400
	Old news, printed wood free		0.3	380

Source: Japan TAPPI Journal

The progress of the technology for an effective use of waste paper in the pulp and paper industry is quite remarkable. Figure4 illustrates the consumption rate in the world. It shows that energy conservation of the pulp and paper industry in the world is making a steady progress.

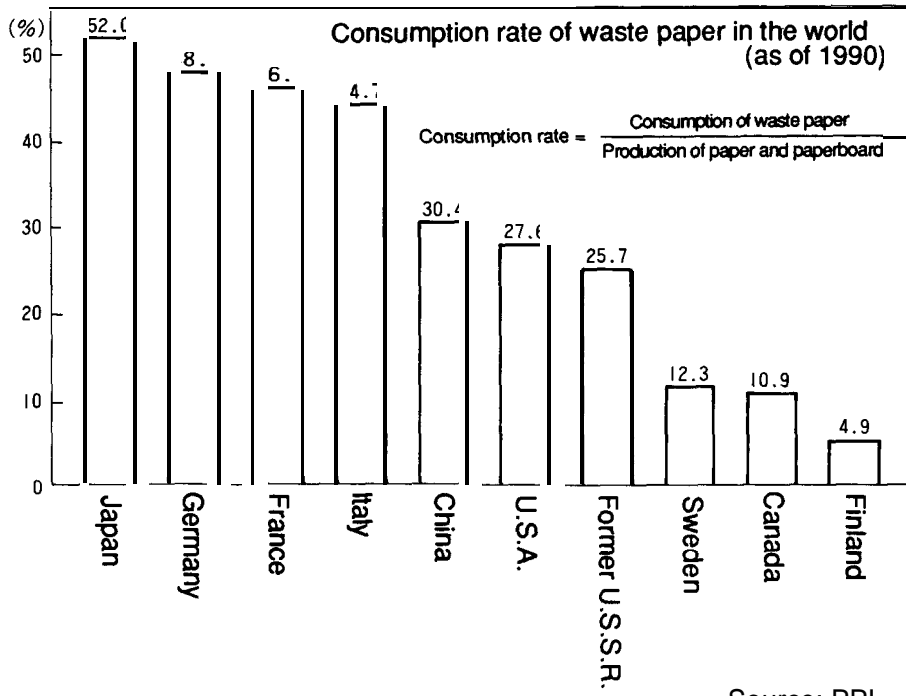

Figure 4 Consumption rate of waste paper In the world

### **3.4 Energy conservation technology in the papermaking process**

The pulp and paper industry as a process industry is required to ensure efficient operation, depending on the control method which provides continuous operation. An improvement of the operation efficiency will lead to the effective use of energy and lowering of the unit consumption.

From the viewpoint of operation efficiency, the energy conservation measures can be reduced to the following points:

- (1) Measures to prevent electric failure at power companies
- (2) Preventive maintenance by the maintenance division
- (3) Prevention of paper breaking
- (4) Effective use of white water
- (5) Improvement of blanket washing equipment, prevention of the blanket and wire net from being contaminated, and material processing measures
- (6) Acceleration of press dewatering
- (7) Acceleration of evaporation in dryer

It is generally felt that there is no remedy for electric failure. A paper manufacturing company which frequently suffers from power failure adopted a private power generation equipment. Since then, it has ensured a stable supply of power completely free from electric failure. Operation efficiency has been increased, while power cost has been reduced to half that of the purchased power. As a result, sales volume and yield have been improved, enabling the company to achieve depreciation in less than three years. This effort has also contributed to the improvement of power situations in local communities and they appreciate it very much.

The process industry cannot enjoy continuous operation without an effective maintenance division. Preventive maintenance (PM) is to prevent accidents in advance and to repair and improve the equipment by a planned equipment maintenance based on the past experience with the equipment failure and by checking the operation through a daily equipment inspection on patrol. It is intended to eliminate the operation shutdown by the maintenance division.

### 3.4.1 Paper breaking

Paper breaking in the paper machine will lead to a waste of energy and reduced yield, causing costs to be increased. It also results in a considerable labor consumption. Paper breaking used to be considered as a matter of course: However, after a detailed analysis of the paper breaking is carried out, the problem will be greatly reduced as a result of improved operator skill, improved equipment ranging from material treatment to paper making process, and introduction of the instrumentation control.

#### (1) Analyzing causes for paper breaking

Figure 5 shows a chart for the characteristic factors which cause paper breaking.

Table 3 illustrates the outline list showing causes for paper breaking and their remedies.

Means to eliminate the possibility of paper breaking can be summarized as follows:

- (a) Removal of shives, sand and other foreign substances
- (b) Control of consistency of fibre in head box
- (c) Improvement of formation
- (d) Uniform pressure to ensure high dewatering efficiency
- (e) Uniform evaporation and drying

The following points should be noted regarding technical problems involved in the equipment:

- a) Selection of the equipment with insufficient functions (selection error)
- b) Equipment not operating in conformity to the specifications
- c) Neglected maintenance, inspection, repair, or performance checking of the equipment therefore, required performances not fully used
- d) Claim against electric failure not submitted to the section in charge inside or outside the company; technical improvement delayed

It is their duty to check if each function is working, to review the operation method and to improve it if something is wrong.

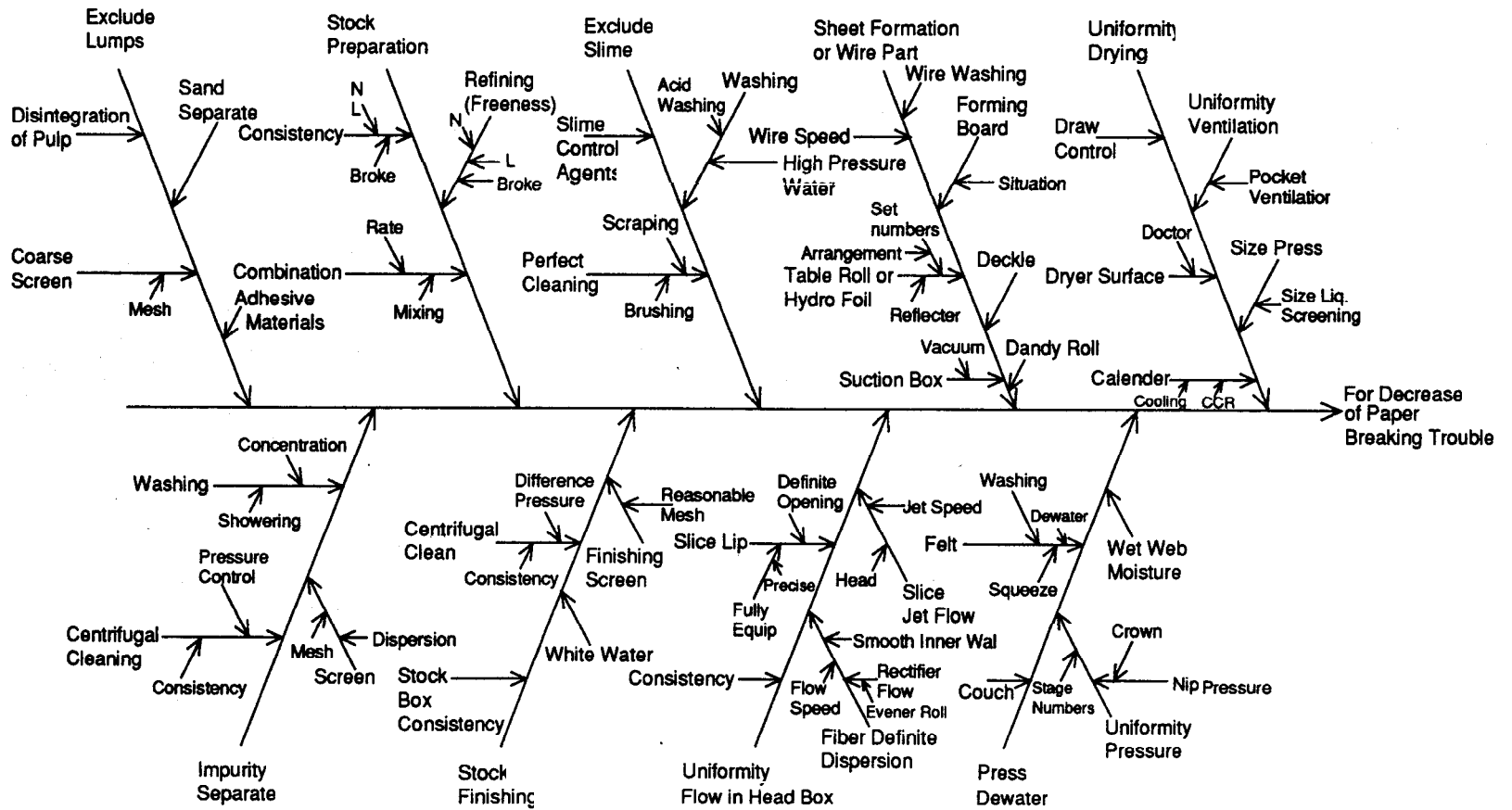

Figure 5 Cause and effect diagram of paper breaking

**Table 3 Causes for paper breaking and remedies**

Places for paper breaking	Classifications	Causes	Measures	Equipment factors
1. Wet part (1) Couch	Fall from couch	Excess Moisture Wet Insufficient strength)	Promotion of dewatering on wire	Dewater rectify on Wire Part Setup of Pick up roll
	(2) Press	crushing Roughened surface on plain roll Mixing of slime Mixing of adhesive substances	promotion of dewatering Roll grinding Removing the slime Separation, removal and dispersion	Grinding Heat kneeding
	Uneven dewatering	Faulty formation Dirty blanket Uneven line pressure	Formation correction Promotion of blanket washing Crown correction	Flow rectify in Head Box & Wire Part Washing, squeeze, dewater. grinding
(3) Wet end	Fall in wet end	Faulty drawing Excessive moisture Mixing of shives Trimming water cutting fault	Drawing adjustment Promotion of dewatering (line pressure increase) Promotion of screening	Setup of high pressure Press Centr, Cleaner, Fine Screen, High Pressure Water Jet
2. Dryer part (1) Yankee Dryer	Breaking due to faulty separation	Paper powder attached Damage on dryer surface	Effective use of the doctor Polishing the surface	Dryer cleaner Bronze Doctor, Dryer Grinding Centricleaner
	Breaking due to intrusion of foreign substances Breaking by tension	Mixing of shives and impurities Faulty drawing Faulty formation	Promotion of screening Drawing adjustment Correcting the formation	Flow rectify in Head Box & Wire Part
(2) Multi Dryer	Breaking by tension Edge breaking	Faulty drawing between groups Edge too dry Mixing of shives and impurities Trimming water cutting fault	Drawing adjustment Improvement of dryer pocket Promotion of screening Water pressure increas	Pocket Ventilation Centricleaner, Fine Screen
3. Calender part	crushing Breaking by foreign substances Breaking in machine directions	Faulty formation Incorrect roll crowing Mixing of shives and impurities Faulty formation and wrinkling Unevey drying and wrinkling	Correcting the formation Correct the roll crown Promotion of screening Improvement of dryer ventilation Correcting the formation Removing the dryer pressure	Flow rectify in Head Box & Wire Part Grinding Centricleaner, Fine Screen

### **3.4.2 Impurities**

Shives, sands, pitches, slimes and deposits are defined as impurities.

Each of the pulping process, material pre-treatment process and papermaking process is provided with the device to remove the impurities. This is because too many troubles are caused by the impurities, and these are very difficult to remove.

#### **(1) Troubles due to impurities**

- (a) Paper breaking may be caused by tension in the contraction process during the wet web drying if impurities are located at the sheet edge.
- (b) Even if pressure is applied to impurities by the press, they contain much moisture and will produce black spots (fish eyes). To remove them, they must be overheated inevitably.
- (c) This may cause the reduction of printing efficiency and even damage of the plate cylinder when the user is printing. This may be the cause for claims against product quality.

Paper breaking will reduce efficiency, yield and production volume, leading to a great energy loss. Fish eyes are often accompanied by much energy consumption due to over-drying; they cause much curling, a poor paper quality and lower yield.

#### **(2) Impurity removing measures**

##### **(a) Equipment**

The coarse screen, centrifugal cleaner and material finishing screen for material pre-processing have pressure and consistency suited to the equipment type. Without relying on the manufacturer specifications, the dust removal rate shall be measured according to the requirements of the process in the plan, and the appropriate work standards shall be set up. Figure 6 illustrates the typical centrifugal cleaner.

The technological advance of the finishing screen is quite remarkable; the slit of 0.07 mm has appeared, contributing to improved quality and reduced paper breaking.

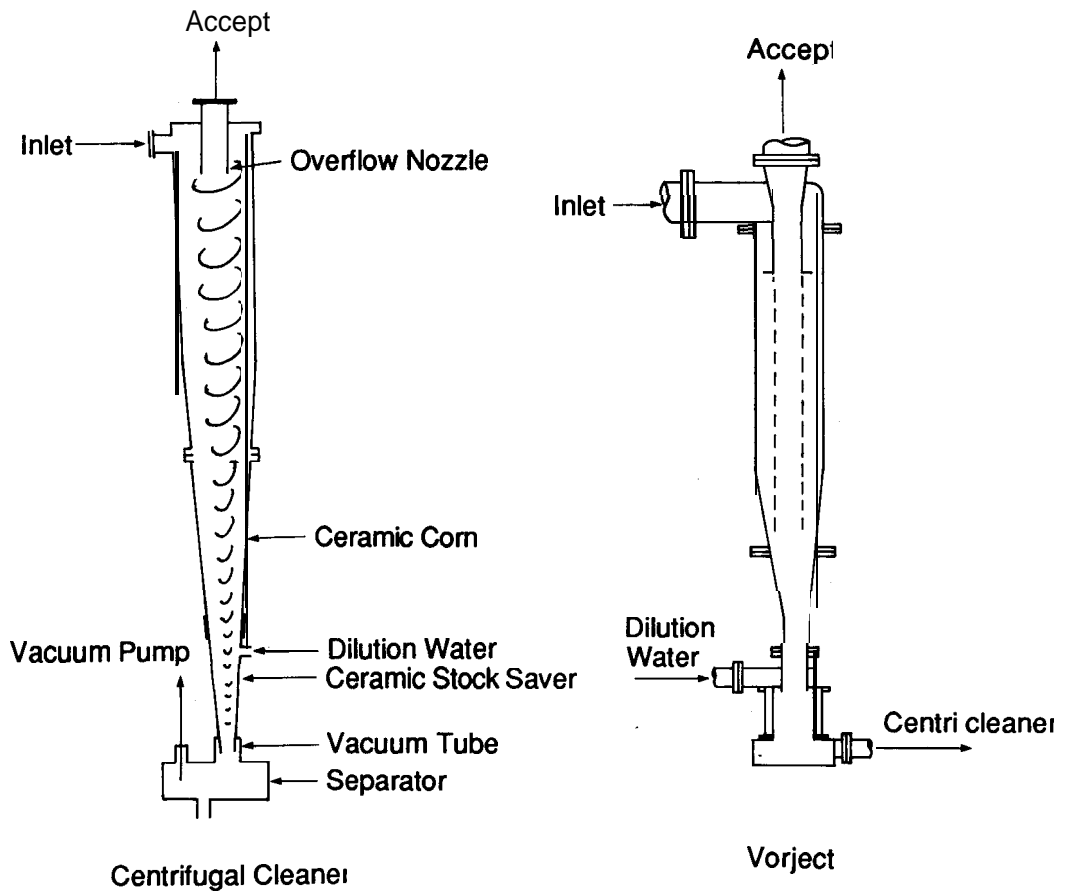

Figure 6 Centrifugal cleaner

(b) Multi-stage removing of impurity

The multi-stage equipment is used when the impurity cannot be removed completely by the one-stage equipment. The impurity removal ratio is measured, and the equipment of the subsequent stage is installed for the existing equipment to provide a multi-stage configuration featuring sufficient capabilities. This will improve the pulp yield and quality and prevent paper from breaking, ensuring an improved overall yield.

(c) Removing the slime and deposits

The refining process and papermaking process provide the optimum conditions for the growth of microorganisms, and deposits are formed in many places. The deposits are especially formed at the positions which are invisible. Deposits must be removed periodically from the following positions by manual brushing or by a scraper:

a) From the fan-pump (large volume and low head pump) to the piping leading to the head box

This position should be provided with the flange connection to facility at cleaning.

b) From the inside of the head box to the lip

Use the wooden scraper so that inner faces will not be damaged. (It must be prepared for this purpose).

c) Side wall of the forming board under the wire, table roll journal, hydro foil, back of the deflector and inner and outer surfaces of save-all devices

The amount of slime will increase if the amount of the circulated white water is increased, and the temperature within the system is raised. When the temperature has reached 45°C or more, there is no growth of deposits.

Note that the slime control agent is not an inhibitor; it does not remove the slime. It should be used for a long continuous operation.

### 3.4.3 Press dewatering

Dewatering in the papermaking machine is achieved by increasing the nip pressure and by applying it uniformly in the cross direction. To ensure effective use of the equipment function, repair, maintenance and adequate modifications must be provided at all times. Care should be taken in the daily control to assure that the press blanket is elastic enough to have a sufficient suction force.

#### (1) Effect of press dewatering

Reducing the wet web moisture by 1% after pressing saves the drying steam of the drier by 4%.

$$W \text{ (kg)} = \frac{(P_w - D_m)}{(1 - P_w)} = \frac{(\text{wet web moisture \%} - \text{paper moisture \%})}{(\text{paper bone dry \% of the wet web})}$$

where,

$P_w$  (%): wet web moisture at press part outlet

$D_m$  (%): wet web moisture at dryer part outlet

$W$  (kg): amount of moisture evaporated from 1 kg of  $d_m\%$  paper

The average of values in the cross direction is used as moisture. The sample should be collected by dividing the total width into several equal parts, and is used for adjustment of moisture deviation and improvement of the press.

Table 4 shows the moisture evaporated from  $P_w\%$  of wet paper in the production of 1 kg of paper, when paper moisture at the dryer end ( $D_m$ ) is 5% or 10%:

**Table 4**

Pw %		65	64	63	62	61	60	59	58	57	56	55
W (kg)	paper moisture: 5% (Dm)	1.71	1.64	1.57	1.50	1.44	1.38	1.32	1.26	1.21	1.16	1.11
	paper moisture: 10% (Dm)	1.67	1.50	1.43	1.37	1.31	1.25	1.20	1.14	1.09	1.05	1.00

When the wet web moisture is decreased from 57% to 56% at the press part, where paper moisture is 5%,

$$\frac{1.21 - 1.16}{1.21} \times 100 (\%) = 4\%$$

‘ Thus, drying steam is reduced by 4%.

Paper moisture of 5% is not effective when consideration is given to the yield.

Assuming the uniform line pressure to be applied in the cross direction, and uniform drying and paper moisture of 10% to be obtained with moisture at the press outlet being 57%, we get the following:

$$\frac{1.21 - 1.09}{1.21} \times 100 (\%) = 9.9\%$$

This will save steam for drying by about 10%. Furthermore, the yield is also improved by 5%. Combined with the advantage of energy conservation, a substantial cost reduction is achieved.

**(2) Other effect of improving the dewatering rate**

For the mechanical pressure of the press, the following advantages are obtained by improving the density between the paper layers:

- a) The strength of the wet web is increased, and the breaking of the wet web between press part and dryer part is minimized.
- b) The surface strength is improved, and the shives attached to the dryer surface are reduced by the numbers, ensuring a higher paper quality.
- c) Uniform dewatering removes sag from the open draw part, and dryer wrinkles are minimized.
- d) The tensile strength, bursting strength and smoothness of the paper are improved.

**(3) Major point for press part dewatering rate**

Figure 7 shows the factors causing press dewatering:

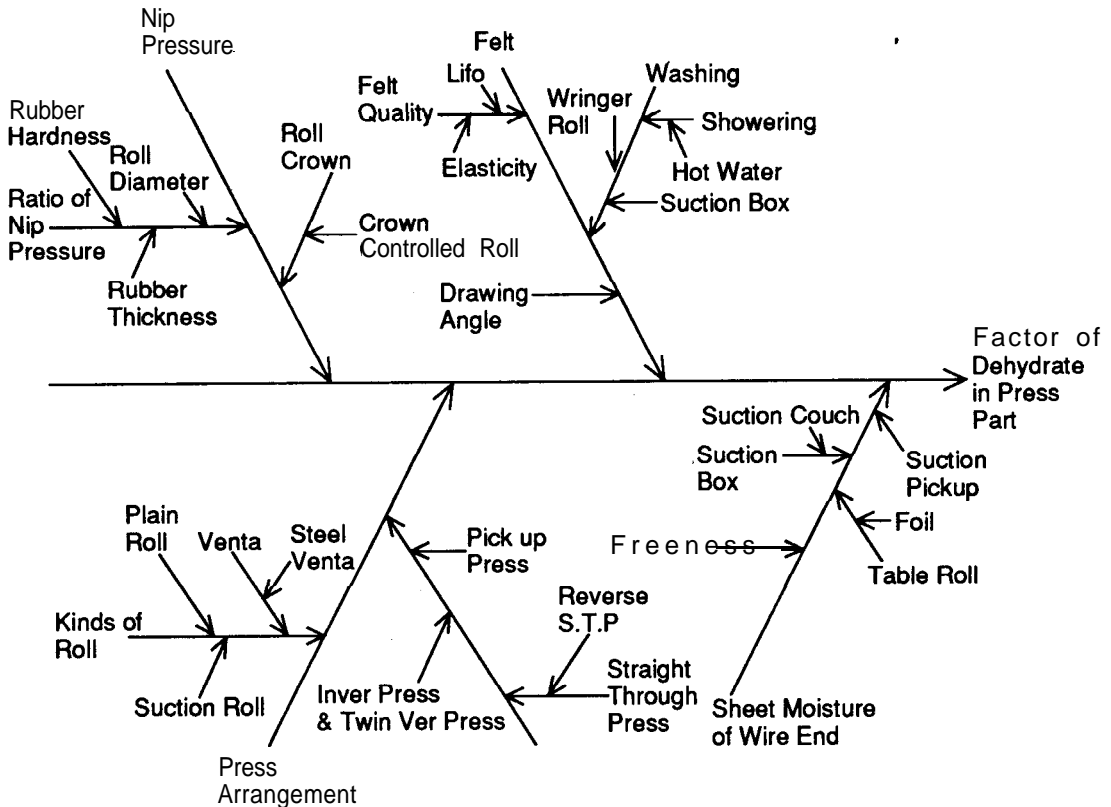

**Figure 7 Cause and effect diagram of press dewatering**

a) Nip pressure and specific nip pressure

When the nip pressure is increased in regular succession, paper moisture is reduced up to twice or three times. After that, the change becomes smaller and smaller until there is no change at all.

The nip pressure effect should be considered as specific nip pressure (nip pressure/nip width).

The nip width depends on the diameter of the rubber roll and the hardness and wall thickness of the rubber. To improve the dewatering rate in the current equipment, the first thing to do is to measure by experiment the locus of the nip width according to the current nip pressure and changed nip pressures and moisture rate divided into several equal parts in the cross direction. This experiment provides the improvement measures to increase the specific nip pressure (nip pressure (kg/cm)/nip width (cm)), the rubber hardness and rubber thickness.

The locus of the nip width can be identified by color development after the application of pressure by inserting the no-carbon paper or special-purpose nip check sheet between the top roll and bottom roll. It can also be used to adjust the roll crown.

b) Roll crown

A pair of top and bottom pressure rolls serve as beams to support both ends, and are bent downward by their own weight. When load is applied to the journals on both ends of the top roll, the roll will bend upward. This brings both ends of the rolls into close contact with each other, but a clearance occurs at the center. As illustrated in Figure 8 (A), the locus of nip width is formed. The roll crown for ensuring uniform dewatering should be determined so that an accurately rectangular form, as shown in Figure 8 (B), will be obtained, having such nip width as obtained from the product quality, papermaking machine, papermaking speed and analysis of the current situations.

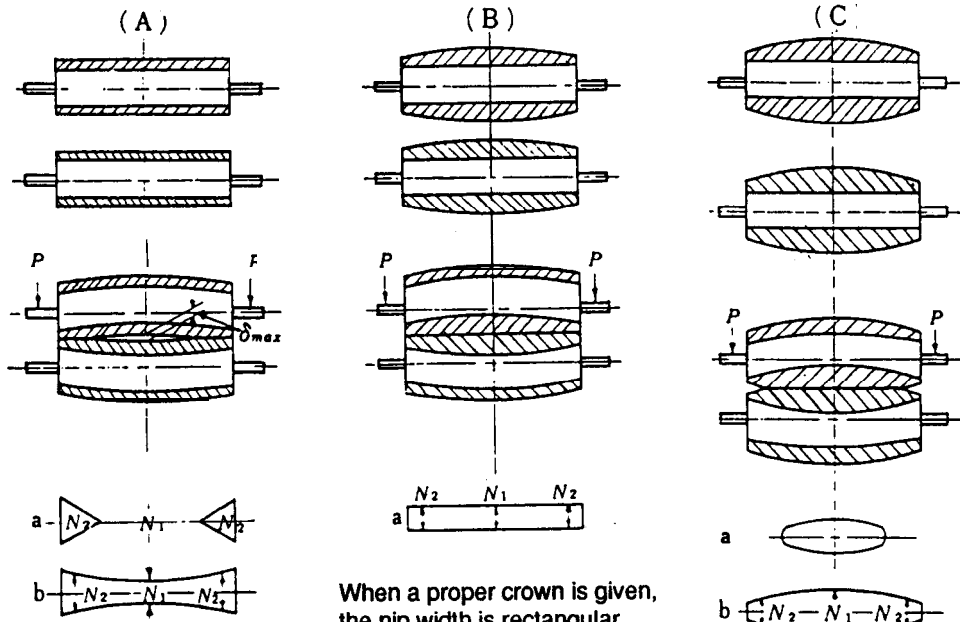

When a proper crown is given, the nip width is rectangular as shown in "a".

When there is no crown or the crown is small, the nip width is as shown in "a" and "b".

When the crown is excessive, the nip width is as given in "a" and "b".

Figure 8 Roll crown and nip width locus

c) Press roll and part arrangement

The press where both the top and bottom rolls are made solid is called "plain press". The press where one or both of the top and bottom rolls are suction rolls is called "suction press" (See Figure 9). The "Venta press" is the press which uses the bender roll (or grooved roll), the surface of which is provided with grooves. Various arrangements are made on the press part which have a great energy conservation effect.

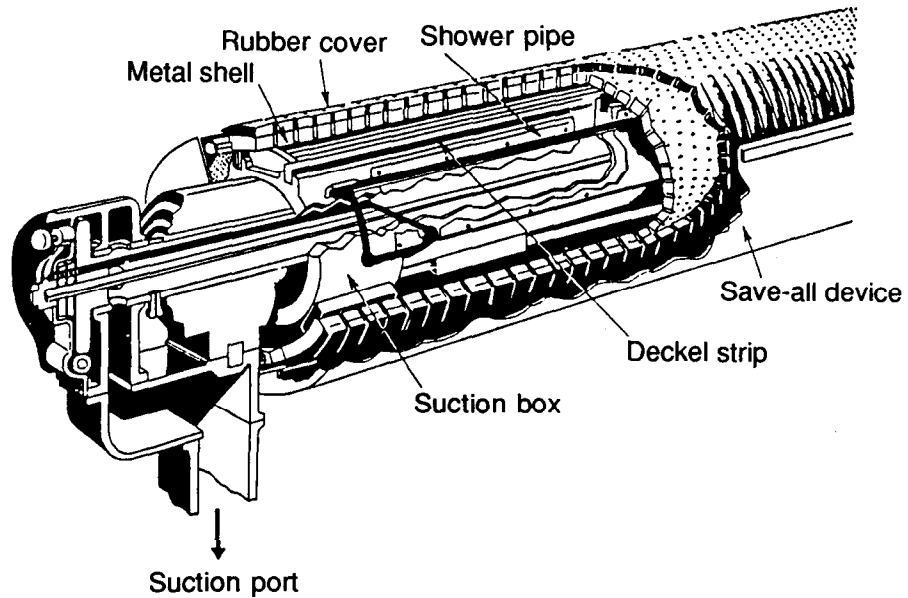

**Figure 9 Suction roll**

The most fundamental type is the straight-through press, which is available with many features; reduced installation area, equipment cost and power cost, prevention of paper breaking, and improved paper surface. Figure 10 shows the typical arrangement.

d) Felt

To minimize the water passing resistance and to ensure the elasticity of the press felt, it is necessary to wash the felt to remove contamination and excessive moisture.

Using the recovered hot water for washing shower is effective not only to increase washing efficiency but also to reduce the wet web temperature.

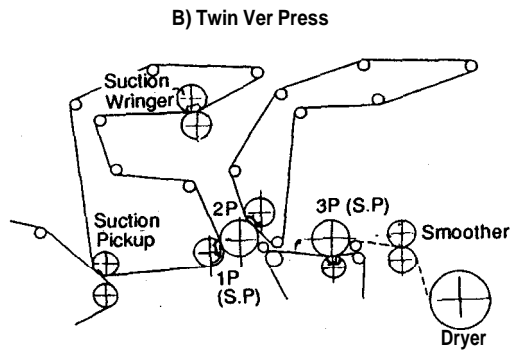
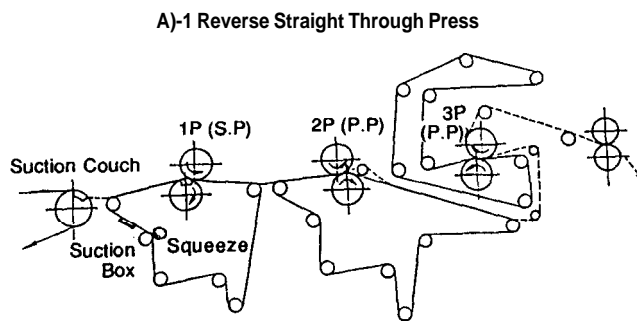
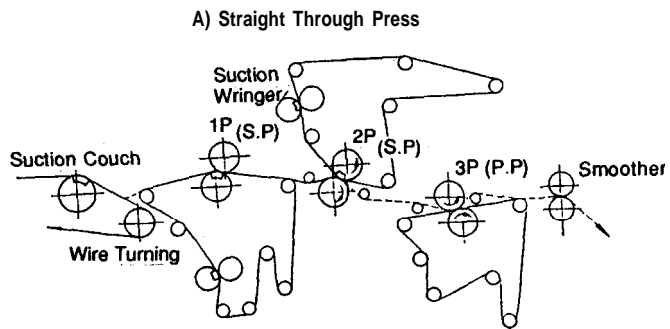

c) Pickup Press (Compact Press)

C)-1 Uni Press

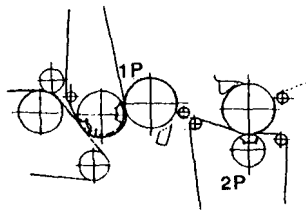

C)-2 Double Pickup Press

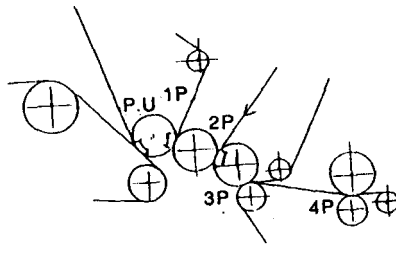

Figure 10 Typical press part arrangement

### 3.4.4 Effective use of white water

There is a close relationship between energy and water consumption in the pulp and paper industry.

The reuse of white water to reduce the amount of new water to be used is a big problem in the low-consistency papermaking process, and is one of the great tasks and responsibilities for the engineers engaged in the pulp and paper industry. There is no equipment which removes completely and continuously fine fibers and filler from a great amount of white water.

The use of new water can certainly be reduced if unique technologies are established by creative consideration for the current equipment and newly introduced equipment according to each kind of products and process.

The pulp and paper industry in the world is making efforts to reduce the amount of water to be used. Table 5 shows the transition of the unit water consumption of the paper mill in Japan.

**Table 5 Transition of the unit water consumption of the paper mill in Japan**

<b>Kind of paper \ Year</b>	<b>1970</b>	<b>1980</b>	<b>1990</b>
<b>General paper (ton/paper ton)</b>	150	95	85
<b>Paperboard (ton/paper ton)</b>	100	50	45
<b>Tissue paper (ton/paper ton)</b>	200	150	120

The unit water consumption of this industry was about 200 tons/paper ton by around 1960, so the value is reduced to a half at present 30 years after that.

Table 6 shows the transition of the unit water consumption in a typical integrated pulp and paper plant where about 150,000 tons of the bleached kraft are produced every year from the wood free paper:

**Table 6 Transition of the unit water consumption and head box temperature**

	1960	1990
Unit water consumption (ton/paper ton)	175	87
Head box temperature (°C)	20	45
Paper machine unit steam consumption (ton/paper ton)	3.6	2.8

It should be noted, however, that the compositions of the product types and quality manufacture requirements are considerably different, and the production volume is also doubled during this period. The annual average water intake temperature is 15.5°C. The rise of the head box temperature indicates the use of circulating white water, thereby reducing the use of new water. It occupies 20 to 30% of the unit steam consumption of a papermaking machine.

**(1) White water belongs to resources.**

The power of pumping up, chest agitator operation and refining is converted into thermal energy, and is stored in the system, where its temperature is increased. Then it is used for steam adjustment.

The white water separated by the concentration filter and wire of the papermaking machine contains fibers and filler, which can be re-used as materials.

**(2) Major points for white water reuse**

The quality and manufacture requirements are different according to each plant, so properties, distribution and freeness of the temperature, concentration, pH value, fibers, filler, etc. are also different. Recovered materials, application of the white water, product quality after use, the manufacturing requirements for fibers must be studied, based on the current analysis value, settling test, and filtering test. Based on the result of this study, flow sheet (See Figure 11) and material balance, water balance (See Figure 12) are prepared. The improvement of the existing equipment and introduction of the new equipment should be determined by a careful study, with consideration given to the opinion of the operator.

Even the equipment which has been installed with consideration given does not always produce the planned performance. It is necessary to make the most effective use of the equipment by repeating the so-called P-D-C-A method (collection of the data and its analysis), as well as improving the equipment. This is the technique. The effective use of white water has the advantages of improved yield, reduction of drain, and reduced drain disposal cost in addition to energy and water conservation.

Figure 11 shows the lifted type fiber recovery machine in the flow sheet, while Figures 13 and 14 illustrate the fine fiber recovery filter.

Figure 12 gives the material balance and water balance around the papermaking machine in terms of model (wrapping paper of 55 g/m<sup>2</sup>, with the daily production of 100 tons, and total efficiency of 100%).

When the shower in the head box and wire washing water (new water) are replaced by the clean white water treated by the white water recovery machine and sand filter, the head box temperature can be increased up to the value of the stock box.

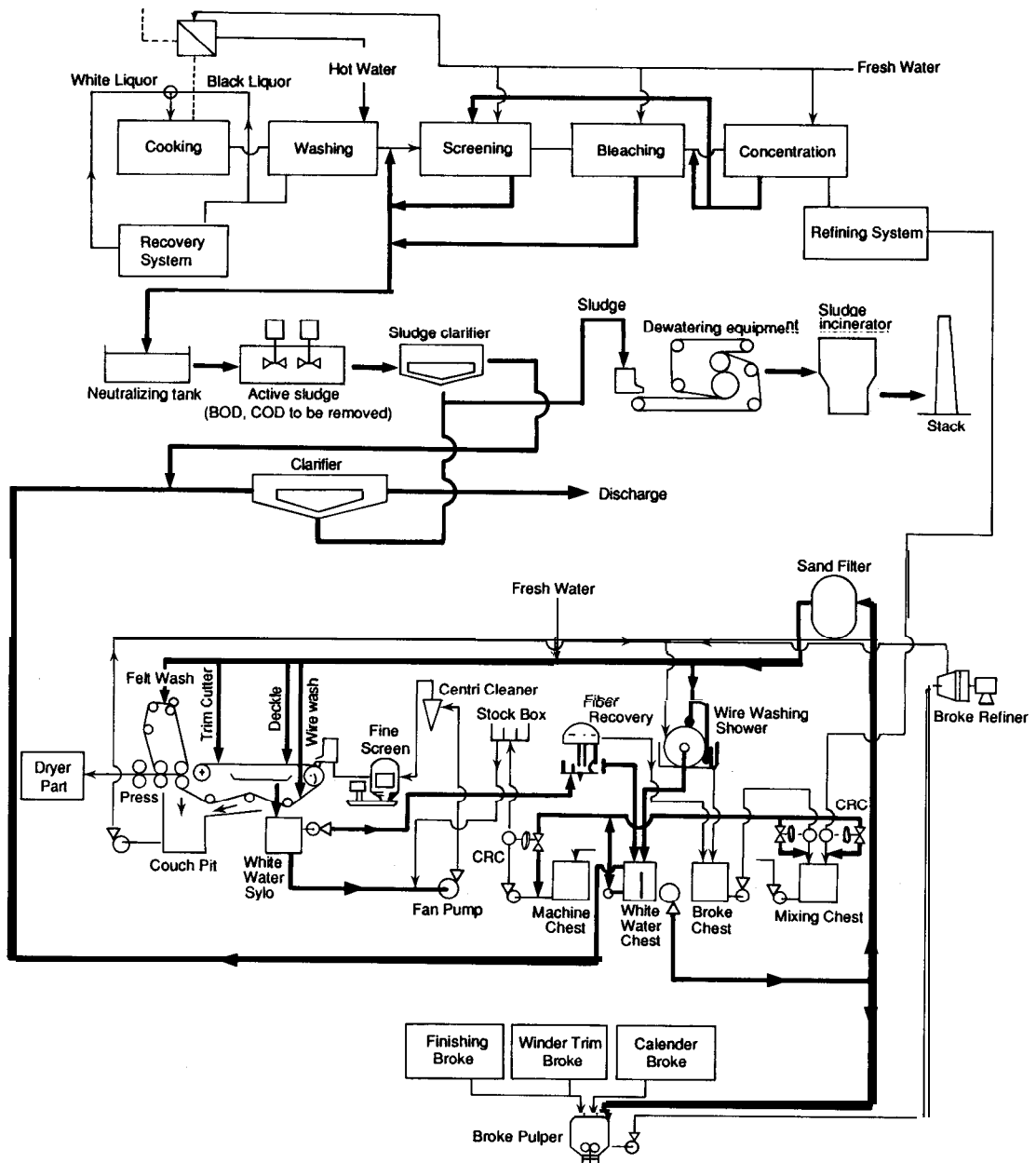

Figure 11 White water recovery and water discharge

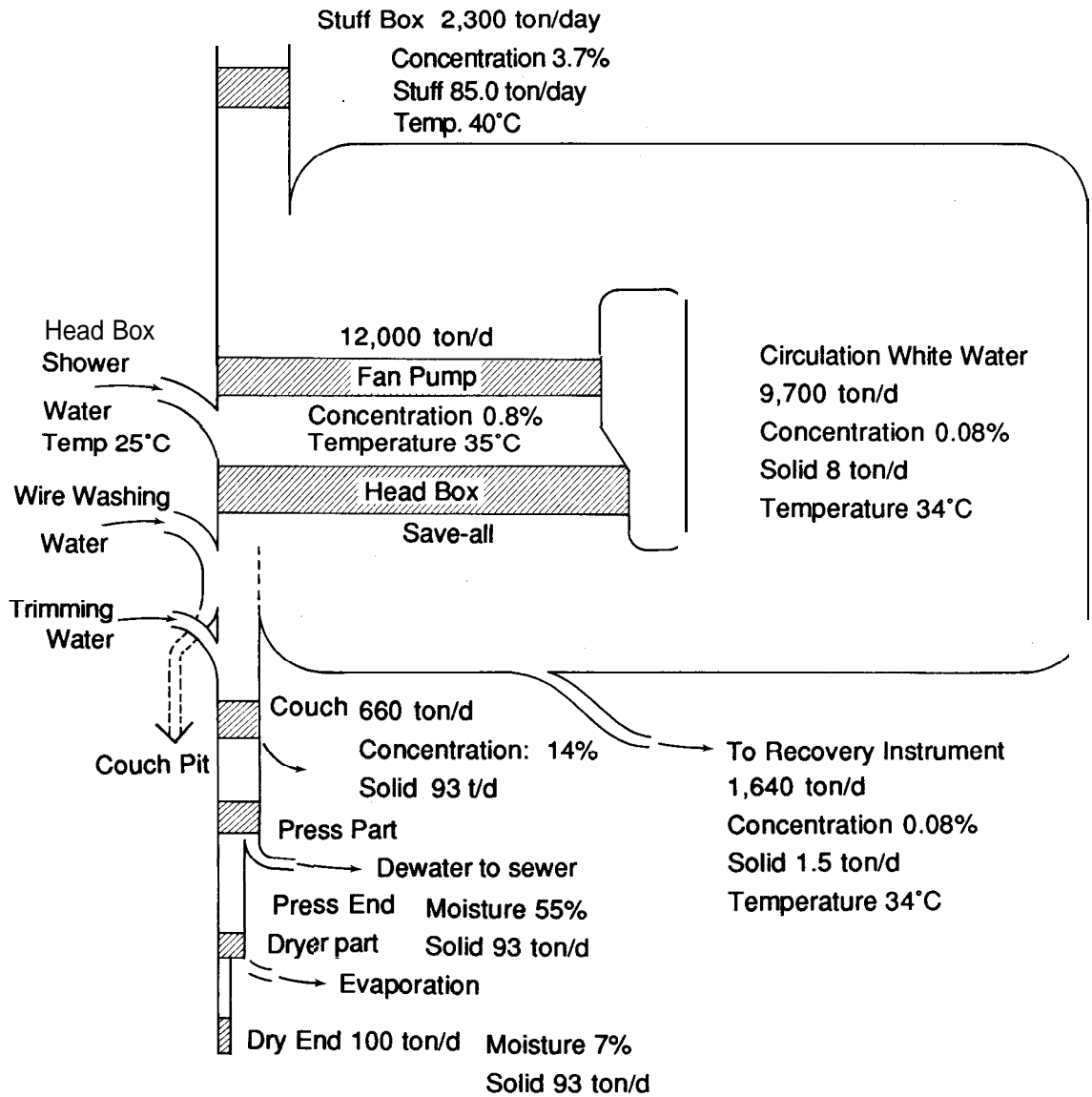

Figure 12 Typical water balance sheet of paper machine

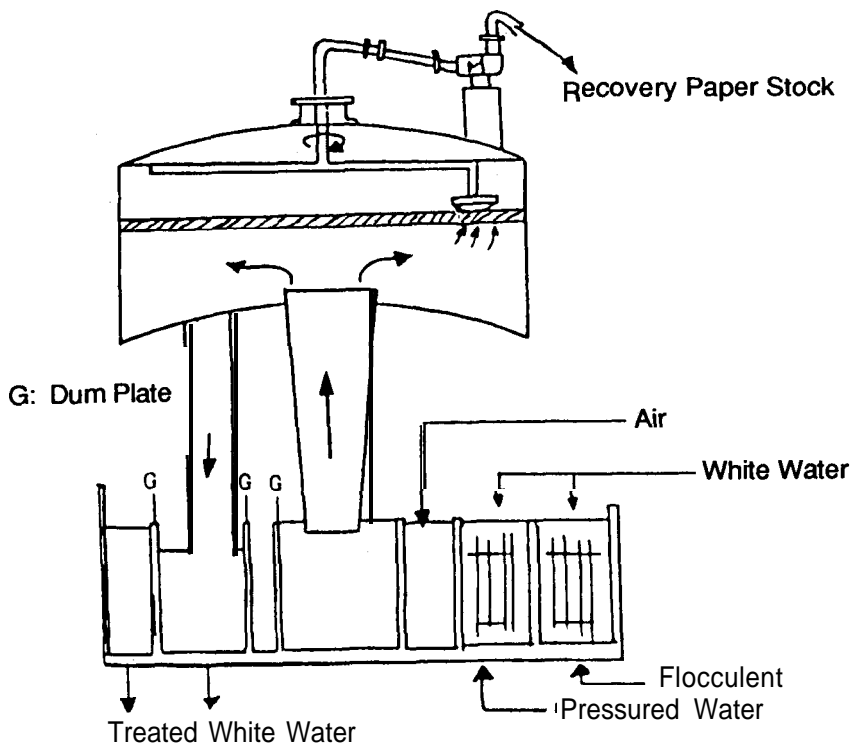

Figure 13 Adka save-all

A) Construction Drawing

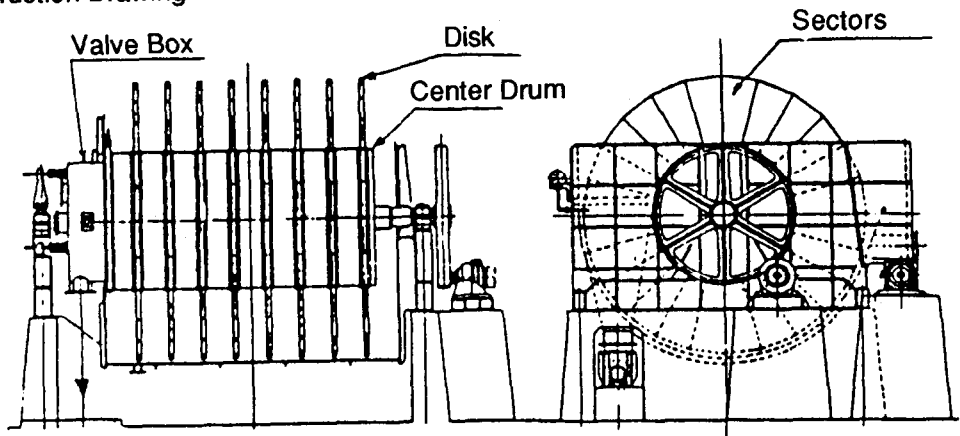

Figure 14 Polydiskfilter

### 3.4.5 Drying

The dryer is the greatest heat consumer in the pulp and paper industry. It is necessary to evaporate almost the same amount of water as the volume of the produced paper. The following introduces the outline of the factors and measures for the effective transfer of supplied energy to the wet paper and efficient evaporation:

Evaporation factor	Measures	Major points
Heat conductivity	Cleaning on the dryer surface  Discharge of drain and non-condensable gas from the cylinder	Effective use of the doctor to remove attached foreign substances  (1) Effective use of the drain discharge syphon (2) Drain and air has poorer heat conductivity than cast iron.
Uneven drying	Pressure control  Temperature control  Installation of BM meter	Pressure control Section and header pressure detection Temperature control Detection of surface temperature by sensor Measurement and control of paper moisture, weight, thickness
Ventilation	Adjustment of air flow line inside the dryer Reduction of thermal resistance, promotion of dispersion Removing the dryer pocket	Correction of hood form  Higher air temperature for dispersion Lower humidity and higher speed  Ensuring uniformity in the cross direction

#### (1) Adjustment of ventilation

The air speed is likely to increase on both edges of the traveling wet sheet of the multi-cylinder type dryer, then, effective drying goes on. A ventilation pocket is formed at the center, so evaporation and drying are delayed. Accordingly, the contraction starts first at both edges featuring quick drying, tension load is applied to both edges and paper breaks. If there exist shives, sands, slime, deposits and other impurities at the edges, paper is very likely to break.

(a) Ensuring uniform moisture

To obtain a uniform moisture profile in the cross direction in the drying process after the papermaking process, it is necessary to meet the requirements of the following intermediate product quality;

- uniform and satisfactory formation on the wire, and
- uniform moisture profile in the cross direction on the press.

After that, ventilation can be controlled easily.

(b) Ventilation control

Figure 15 illustrates the air flow inside the open hood among different dryer hood types and moisture profile in the cross direction.

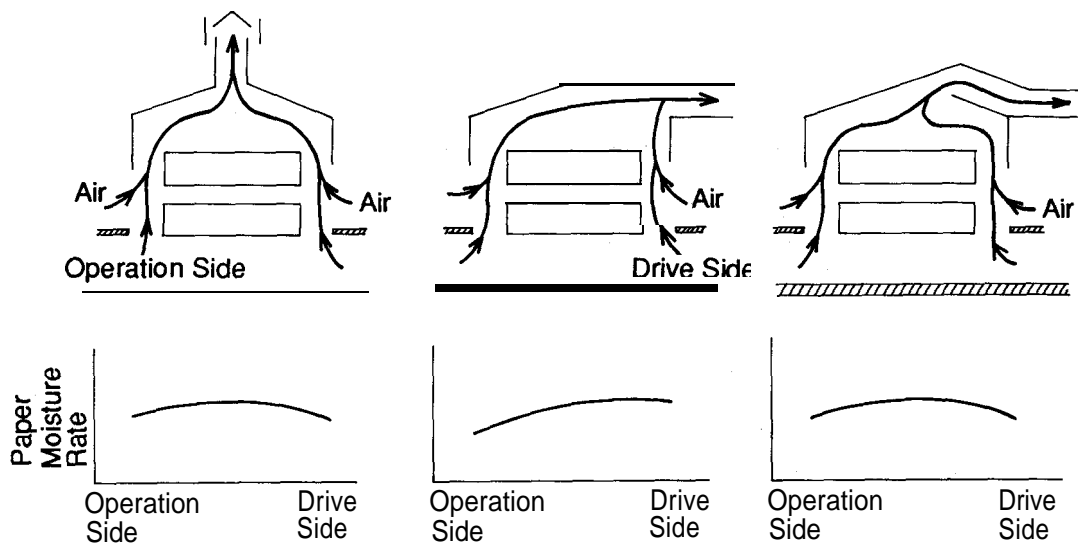

Figure 15 Air flow or paper moisture profile In different hood types

**(2) Effective use of BM meter**

The BM meter is used to control the moisture profile in the cross direction. This is a device to control the profile within the specified range by the combination of basic weight and moisture percentage sensors with the computer, while scanning in the cross direction. Basic weight control is made in the cross direction and machine direction simultaneously. For the control in the cross direction, the calculation is made by the computer, and fan-pump speed or the opening angle of stream flow valve is controlled. Control in the machine direction is made by manual adjustment of the slice lip.

Moisture is controlled by steam pressure control of the dryer section header.

The profile in the cross direction is controlled by the crown control roll (CCR) so that the press nip pressure is uniform. It should be noted that the complete advantages of the BM meter can be used only when the pocket ventilation device is installed.

### 3.5 Energy conservation technology In the pulp refining process

A pulp beating process was made with a beater before 30 years. After that, a larger capacity and labor saving requirement of a paper making machine follows a continuous beating machine, that is a refiner. The types of a refiner are a conical type, a drum type and a disc type as shown in Figure 16.

Conical type refiner

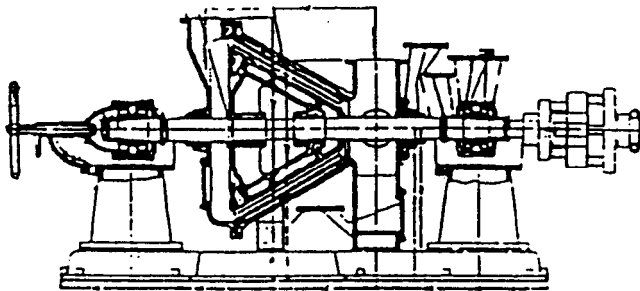

Drum type refiner

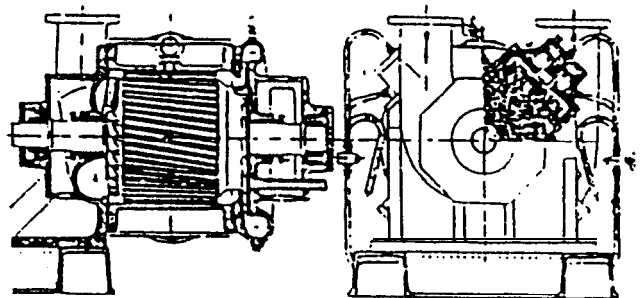

Disc type refiner

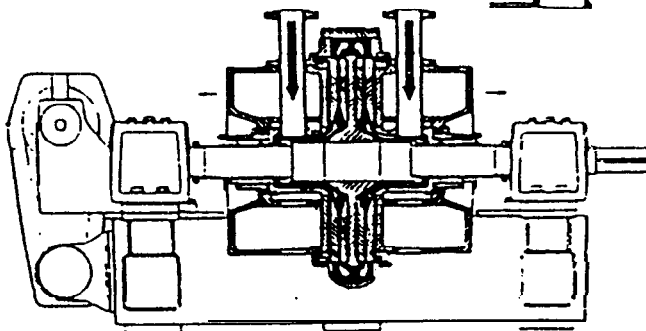

Figure 16 Types of a refiner

1) Conical type refiner

A conical type refiner consists of a conical fixed shell and a conical rotor with bars on the surface of the rotor.

2) Drum type refiner

A drum type refiner consists of a drum rotor and a stator. Most of rotor is made from stone. Fibril process is made without cut of fiber.

3) Disc type refiner

A disc type refiner consists of a sliding disc and a rotary disc. As the number of bar edge per unit area can be increased, energy utilization is high. A double disc refiner (DDR) can make the unit energy consumption lower than a single disc refiner. The select of a plate design such as the width of bar can be easy, so the quality control is easy.

### 3.5.1 Unit power consumption of refiner

In a conical type refiner, a drum type refiner and disc type refiner, electricity consumption which is required to reduce the freeness (Canadian Standard Freeness Method) is shown in Figure 17. The unit electricity consumption is shown with kWh per 100cc drop. The unit electricity consumption of double disc refiner is lower than that of the other type refiner in NBKP and LBKP.

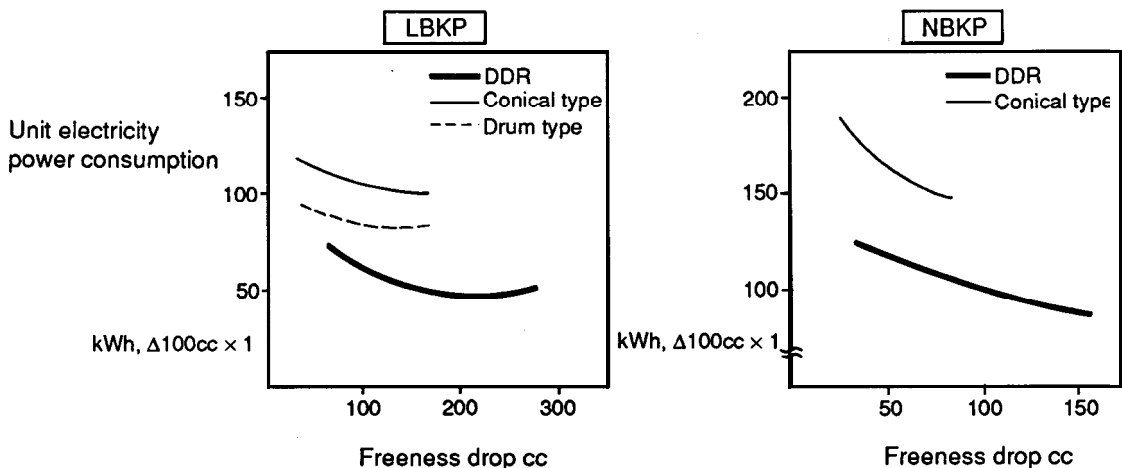

Figure 17 Comparison of unit electricity power consumption

### 3.5.2 Effective refining energy

Refining process effects the strength and surface condition in the quality of paper. The beating power is saved with operation control according to the equipment specifications. The effective beating energy ( $W_e$  kWh/t) is as follows:

$$w_e \text{ (kWh/t)} = \frac{\text{Effective beating power (kW)}}{\text{Pulp volume (B.D. ton/h)}}$$

Where,

Effective beating power (kW) = Motor load power (kW) - No-load power (kW)

Pulp volume (B.D. ton/h) = Passing quantity bone dry pulp per hour

It is important for the effective use of beating energy to control the pulp density and the pressure at the inlet and the outlet of a refiner as specified. The pulp density is around 4% in general. The pressure at the inlet of a refiner is 1.0 to 1.5 kg/cm<sup>2</sup> and the pressure at the outlet of a refiner is 1.0 to 1.5 kg/cm<sup>2</sup> higher than that at the inlet in general. To control these factor, a density controller is installed in the inlet of a refiner. It is good to use a flowrate controller as a density controller, but it is necessary to keep constant flowrate at a headbox. The characteristic figure of refining process is freeness. The factors are the pressure at the inlet and the outlet and the beating power of a refiner. It is necessary to install pressure gages at a refiner. The instrument related to the characteristic figures must be installed and be kept in the normal condition.

#### 4. Energy conservation in the pulp and paper industry

To meet the economic' growth, market quality requirements are getting more severe and diversified. These quality requirements often make it essential to use much energy. Figure 18 shows the trend of the energy conservation under this situation.

(index [1980 = 100])

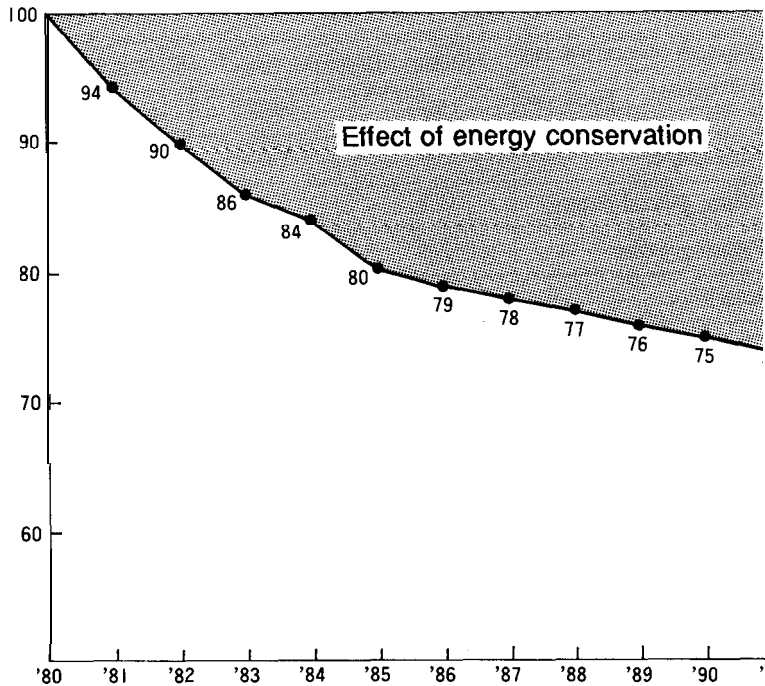

**Figure 18 Transition of unit consumption in Japan**

For the solution of this problem, the papermaking process mainly depends on increased efficiency, while the pulping process depends on equipment improvement.

## 4.1 Energy conservation in the papermaking process

Table 7 shows the energy conservation in the papermaking process regarding steam and electric power unit consumption for the paper and paperboard, and this data is based on replies from the questionnaire sent by the Japan Paper and Pulp Technology Association.

**Table 7 Steam and electric power unit consumption rate for the paper and cardboard manufacturing process in Japan**

		Unit consumption rate		Electric power (kWh/paper ton)	
		Fiscal year		1980	1988
Type		1980	1988	1980	1988
Paper	Newspaper	2.0	1.8	550	530
	White glazed paper	3.1	2.8	1060	940
	Printing paper	2.5	2.3	760	700
Paperboard	Jute liner	2.3	1.8	500	440
	Coated manila board	2.9	2.5	400	540

Printing paper and coated manila board are required to meet severe quality requirements on the suitability for printing. Energy conservation is carried out smoothly, although it contains many factors which are disadvantageous to the unit consumption rate. This is due to the efforts for efficiency improvement based on the following management policy:

“Followed by sales people, the production program with major emphasis placed on operation efficiency of the paper machine”

The production plan in the factory is worked out by studying how to reduce the manual replacement time, while major emphasis is placed on the order of manufacturing processes. The sales people facing users promote sales activities according to this plan, and this uniform concept also promotes the field technology in results.

For the newspaper and printing paper, continuous operation for 25 to 40 days is normal. Paper breaking occurs only 0.1 to 0.2 times a day, according to some reports. Further efforts for higher efficiency and effective use of the white water will be made.

## 4.2 Energy conservation In the pulping process

Energy conservation in the pulping process has registered a remarkable record in the KP method (kraft pulp). The transition of the unit consumption is as shown in Table 8.

In the pulping process, the introduction of new equipment leads to a reduction of the unit consumption.

**Table 8 Comparison of specific energy consumption for KP pulping**

		Steam Unit: t/pulp t		Electricity Unit: kWh/pulp t	
Cooking	FY	1980	1988	1980	1988
	N	1.2	1.0	230	220
	L	1.0	0.8	130	120
Evaporation	N	1.5	2.0	100	90
	L	1.9	1.4	100	90
Bleaching	N	0.8	0.4	260	220
	L	0.6	0.3	170	140

### (1) cooking process

One of the major factors for the reduced unit consumption in the cooking process is the parallel installation of continuous digesters in many cases. Table 9 shows a comparison of the unit consumption for batch digester and continuous digester:

**Table 9 Comparison of specific energy consumption in batch digester and continuous digester**

		Steam Unit: t/pulp t		Electricity Unit: kWh/pulp t	
Batch Digester	FY	1980	1988	1980	1988
	N	1.45	1.3	200	215
	L	1.1	1.1	120	115
Continuous Digester	N	1.1	0.75	240	220
	L	0.9	0.7	130	115

The continuous digester has a smaller steam consumption but a greater power consumption than the batch digester.

The yearly reduction of unit consumption for steam and electric power is due to a gradual improvement of the continuous digester and its operation technique.

## (2) Concentration process

Table 10 shows the difference between the unit consumption for steam and electric power of tube type and plate type for the black water concentration evaporator. Since the plate type is based on gravity flow, the pump power is small, permitting easy turning down, quick removal of scales and high operation efficiency.

**Table 10 Comparison of unit energy consumption for KP pulping**

		Steam Unit: t/pulp t	Electricity Unit: kWh/pulp t
<b>Tube type</b>	N	1.7	125
	L	1.65	90
<b>Plate type</b>	N	1.4	75
	L	1.25	80

## (3) Saving new water

In Japan, the amount of water used recorded a remarkable decrease since about 1970 when the pollution prevention law was enacted. This trend was further accelerated when Japan faced the primary and secondary oil shocks in 1973 and 1978 respectively. Figure 19 shows the transition of unit consumption for the amount of new water used to manufacture paper and paperboard products.

The use of circulating white water has increased the head box temperature to 40 to 60°C in many cases. The improved dewatering efficiency and steam unit consumption have also made a great contribution.

---

**N: Needle-leaved tree (Coniferous tree)**

**Neblebaum in German**

**L: Broad-leaved tree**

**Laubbaum in German**

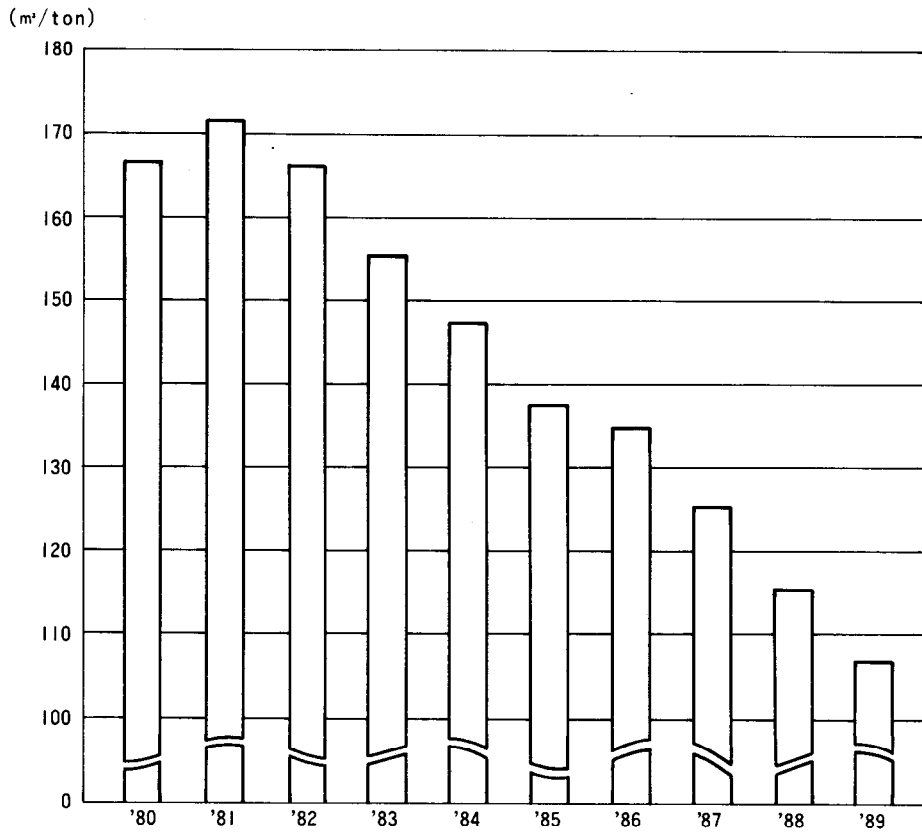

Source: Industrial Statistics Table, Volume for Land and Water,  
Year Book of Paper and Pulp Statistics

**Figure 19 Transition of unit consumption for the amount of new water used to manufacture paper and paperboard products**